

Appendix 1

System Treatment System Fact Sheets

System Type: Septic Tank to Soil Absorption Trenches

Basic design: Septic tanks to soil absorption (leaching) trenches are the most common system installed in Ohio. These system typically consist of a 1,000 to 2,000 gallon septic tank that may be divided into one or two compartments. The tanks are manufactured from precast concrete, polyethylene plastic, or fiberglass. The septic tank provides some treatment of the effluent from the house by allowing for the settling of solid materials, and separation of scum, fats and greases. The partially clarified liquid, or effluent, is then drained by gravity to plastic perforated pipes laid in gravel trenches in the soil. The trenches are typically installed from 18-30 inches deep, but shallow depths of 8-18 inches are also permitted. Other types of alternative aggregate or chamber products can be used in place of perforated pipe and gravel to distribute effluent in the trench. The soil is used as the primary treatment media to remove the smaller suspended particles (TSS) and organic material (BOD). Research confirms that 2 to 4 feet of unsaturated soil is needed to completely remove bacteria, viruses and protozoans from sewage.

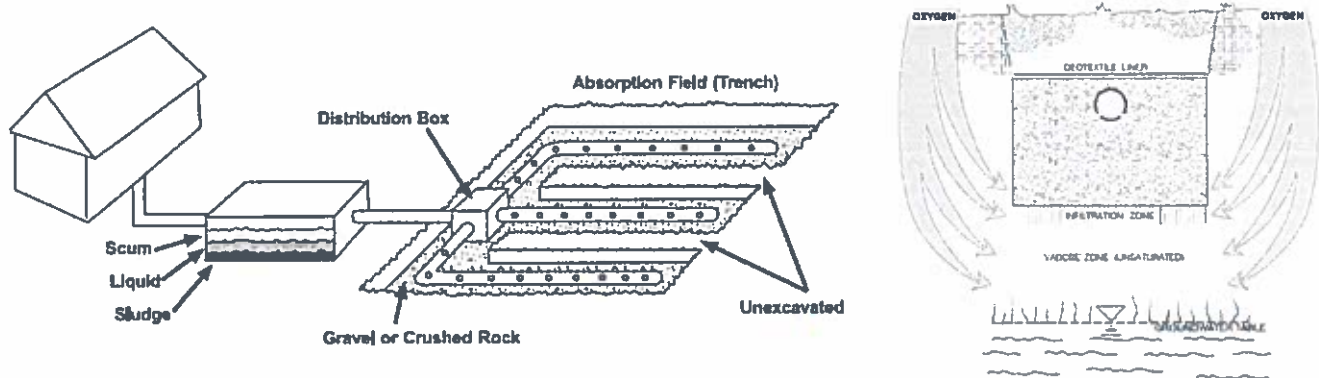

Advantages: Septic tank to soil absorption trenches are passive, simple and low maintenance systems. They can effectively treat sewage and their performance has been extensively studied. They are also a reasonably priced system where soil conditions permit their installation.



Alternative aggregate or chamber products.

Disadvantages: These systems require soils that are not seasonally saturated with water to ensure treatment, and prevent ponding or nuisance conditions in yards. Over time, the soil absorption trench will develop a biomat consisting of suspended particles, organic matter and bacterial slimes which will eventually clog the trenches and lead to system failure. Lowering the amount of suspended particles, organic and bacterial load to the trenches by pretreating the wastewater can help extend trench life.

Operation and Maintenance: Regular pumping of the septic tank (every 2-5 years) at a cost of approximately \$50-100 per year.

Average Regional System Costs:

Region/Cost	Northwest	Northeast	Southeast	Central	Southwest
2007 LHD Permits	\$6,000 – 8,000	\$7,000 – 10,000	\$5,000 – 6,000	\$7,000 – 8,000	\$6,700-8,000
2007 Installer Survey	\$7,800	\$11,000	\$7,000	\$6,300	\$8,000

Pretreatment to Soil Absorption Trenches

Basic Design: This system design includes a mechanical pretreatment device that reduces the suspended solids, organic material and bacteria in the effluent. Pretreatment devices consist of a special septic tank that is divided into two or more sections to provide for settling of solids and effluent treatment. These devices use different biological processes to treat sewage including continuous flow, suspended growth aerobic systems (most common), fixed media processing and optional recirculation, and sequencing batch reactors. Aerobic conditions are required for treatment, subsequently most systems add oxygen to the treatment process. These systems can substantially reduce the total suspended solids (TSS), organic matter (BOD), fecal coliform (and other pathogenic bacteria). Some systems use recirculation of effluent to reduce ammonia and nitrogen in the effluent. The treated effluent is discharged to a soil absorption trench. Due to the high level of pretreatment, the size of the soil absorption trench can be reduced by 25 to 30%, thus reducing system costs. The significant reduction of fecal coliform can also allow for less thickness of soil necessary for treatment, and one or two foot soil depth credits (reduction of soil thickness needed by 1-2 feet) can be used to help overcome site limitations such as bedrock or seasonal high water table.

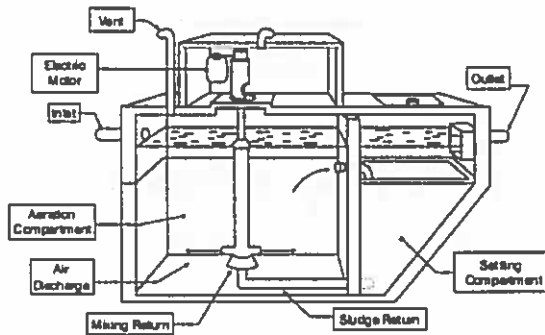

Typical aerobic treatment unit

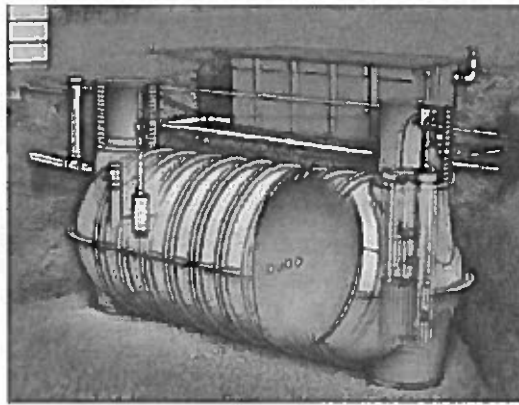

Fixed film pretreatment unit

Advantages: A variety of pretreatment units are available across the state with varying costs, performance levels and operation and maintenance requirements. Pretreatment devices help overcome site limitations like high seasonal water table by providing higher levels of treatment to allow for less useable soil thickness on the lot. They also ensure adequate treatment when the system is located near or could impact sensitive water environments. These devices also allow for a smaller area for the soil absorption trenches reducing costs.

Disadvantages: Pretreatment units are mechanical devices that require regular maintenance by a qualified service provider.

Operation and Maintenance. Annual maintenance costs can range from \$100 to \$250 per year. Maintenance requirements will vary by system. Some systems offer or require remote telemetry to monitor system operations.

Average Regional System Costs:

Region/Cost	Northwest	Northeast	Southeast	Central	Southwest
2007 LHD Permits	\$8,300	\$8,200	\$7,000	\$9,500	\$11,000
2007 Installer Survey	\$9,200	\$12,000	\$8,600	\$7,900	\$11,200

System Type: Sand Mounds with Pressure Distribution

Basic Design: A septic tank and sand mound system is a technology used for treating and disposing of wastewater in areas unsuitable for conventional septic tank soil absorption systems. Mounds are pressure-dosed sand filters placed above, and discharging directly to, the natural soil. Their main purpose is to provide additional treatment to the wastewater before it enters the natural environment. Treatment occurs through physical, biological, and chemical means as the wastewater filters down through the sand and the natural soil. Mound systems are designed to overcome site restrictions such as slow or fast permeability of soils, shallow soil over bedrock, and a perched seasonal water table through elevation of the system with sand. The three components of a mound system are a septic tank or pretreatment unit(s), dosing chamber, and the elevated mound. Some mound systems are designed with a pretreatment unit(s) to reduce waste strength and/or to reduce the mound sizing. The dosing chamber follows the septic tank or pretreatment component and contains a pump, which uses pressure to evenly distribute the wastewater over the infiltration surface of the mound. The mound is constructed with a soil cover that can support vegetation, and a fabric covered coarse gravel aggregate or gravelles product in which a network of small diameter perforated pipe is placed. The network of perforated pipe is designed to distribute the effluent evenly through the gravel from where it trickles down to the sand media and hence, into the plowed basal area (natural soil).

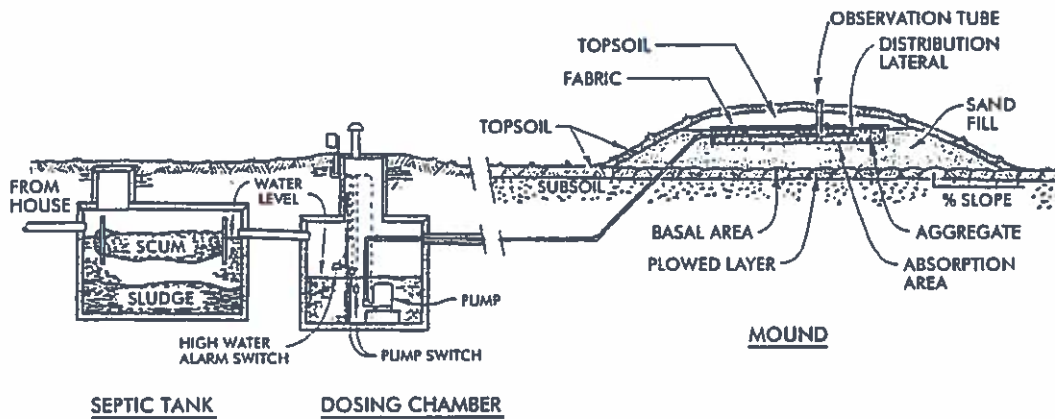

Source: ASAE, Converse and Tyler, 1998b.

Advantages: Mound systems enable the use of some sites that would otherwise be unsuitable for in-ground or at-grade onsite systems due to seasonal perched water or other site limitations. The natural soil utilized in a mound system is the upper most horizon, which is typically the most permeable. A mound system does not have a direct discharge to the ground, streams, or other bodies of water; and construction damage is minimized since there is little excavation required in the mound area.

Disadvantages: Cost is somewhat higher a conventional systems due to specialized construction, materials and transportation costs, and possible engineering design fees; since there is usually limited usable soil available at mound system sites, extreme care must be taken not to damage this layer with construction equipment; the size and shape of mound systems, and their elevation above the natural grade may present some concerns related to grading, landscaping and aesthetics for the site.

Operation and Maintenance: Suggested annual inspection of mechanical components and flushing of distribution pipe to remove bio-slimes/build-up at a cost of \$150-\$300 annually. Regular pumping of the septic tank (every 2-5 yrs) at a cost of \$50-\$100 annually.

Average Regional System Costs:

Region/Cost	Northwest	Northeast	Southeast	Central	Southwest
2007 LHD Permits	\$12,000	\$15,000	\$7,200	\$14,700	\$17,800
2007 Installer Survey	\$15,000	\$18,000	\$18,000	17,000	\$22,500

System Type: Peat Biofilter with Soil Absorption

Basic Design: A peat filter produces secondary-level treatment of septic tank effluent by filtering it through a layer of sphagnum peat before sending it to the soil absorption system. Peat is partially decomposed organic material with a high water-holding capacity, large surface area, and chemical properties that make it effective in treating wastewater. Unsterilized peat is also home to a number of different microorganisms, including bacteria, fungi, and tiny plants. All of these characteristics make peat a reactive and effective filter. The peat is contained in modules placed above ground or at ground level. Wastewater flows into a septic tank where the large solids settle out. The liquid effluent either gravity flows, or in some models, is pumped in doses to the peat filter where it is pretreated and delivered to the soil absorption system for final treatment. Depending on the installed depth of the peat filter, a dose pump may be required to lift effluent to the soil absorption system. With a gravity distribution to the filter, wastewater may pond on top of the peat compressing it, reducing the flow of wastewater through the filter. With a pressure distribution system, wastewater is applied evenly over the peat surface, allowing rapid infiltration. Due to the high level of pretreatment, the size of the soil absorption trench can be reduced by 25 to 30%, thus reducing system costs. The reduction of fecal coliform can also allow for less thickness of soil necessary for treatment, and one or two foot soil depth credits (reduction of soil thickness needed by 1-2 feet) can be used to help overcome site limitations such as bedrock or seasonal high water table.

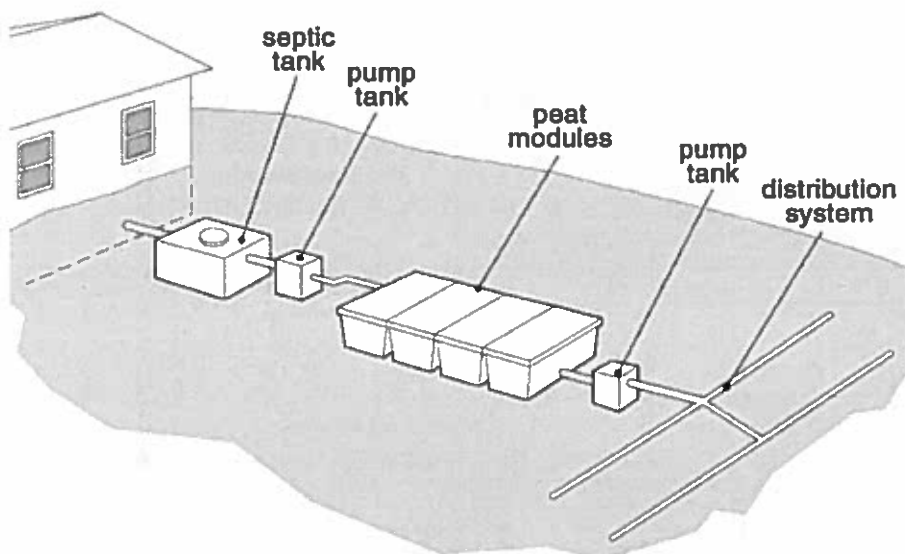

Advantages: Peat's high cation exchange capacity means the peat can effectively hold positively charged molecules including ammonium, metals, pesticides, some organic molecules, and possibly viruses. As a filter medium peat is effective in situations where loadings are seasonal or intermittent. The treatment capacity can be expanded through modular design.

Disadvantages: Peat filters require more maintenance than conventional septic to soil absorption trenches. Treatment media has a limited useful life of 10-15 years and has to be replaced with new media depending

on the use.

Operation and Maintenance: A maintenance contract is recommended; the system may require quarterly to yearly maintenance. Maintenance includes inspecting all components and cleaning and repairing when needed. The peat module(s) are low-maintenance and require no annual pumping or backwashing. They should be raked annually to break up any biomat that may be forming and to level the media. Because of the high organic content of peat, the filter media must be periodically replaced. Life expectancy of the peat media in a filter is estimated to be ten to fifteen years. Daily running costs for a peat filter are based on the operation of a small submersible pump, and average less than one dollar per month for an individual home (2002). Overall operational costs of \$200-\$500 per year include pumping, repairs, maintenance, and electricity.

Estimated Statewide System Costs: \$10,000 to 15,000 (no permit data collected for this system type)

System Type: *Single Pass Intermittent Sand Filter/Bioreactor*

Basic Design: Single Pass Intermittent Sand Filters (ISFs) are fixed-film biological treatment units. In ISFs, wastewater is applied in intermittent doses to a bed of sand or other suitable media. The wastewater first receives primary treatment in a septic tank or an aerobic treatment unit, and then is pumped from a screened vault in the septic tank or separate dosing tank to the water-tight lined sand bed or module where it is evenly distributed over the top of the sand filter bed. Media alternative to sand has been utilized in some designs. As the wastewater passes through the sand filter, treatment is accomplished by physical, chemical and biological actions. The main treatment is accomplished by the microorganisms attached to the filter media. The treated wastewater is collected in underdrains at the bottom of the sand filter and is then transported to the soil absorption system. ISFs are designed such that the pretreated wastewater passes through the sand filter bed once. With proper design and media sizing ISF's achieve reductions in biochemical oxygen demand (BOD), total suspended solids (TSS), and fecal coliform. However, this pretreatment device has not been approved in Ohio for soil absorption or soil depth credit reductions.

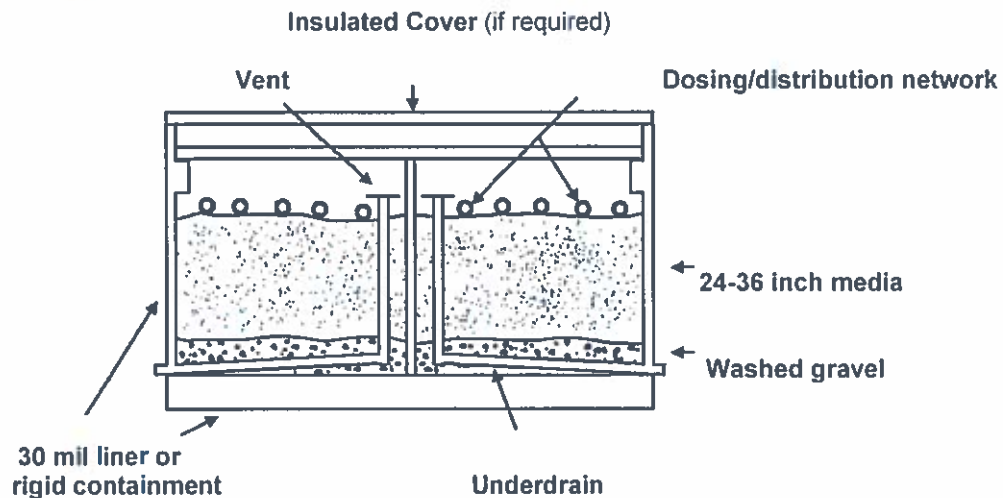

Advantages: Intermittent Sand Filters (ISFs) are simple in design and relatively passive to operate because the fixed-film process is very stable and few mechanical components are used. High flow variations after equalization in a septic tank are not a problem because the residual peaks and valleys are absorbed in the pressurization tank or in the last compartment of the preceding septic tank. A malfunctioning ISF backs up rather than release poorly treated effluent. ISFs tolerate fluctuations in flow, especially changes from negligible flow to very high flows thus are appropriate for seasonal use. Construction costs for ISFs are moderately low, and the labor is mostly manual.

Disadvantages: Cost is somewhat higher than those of conventional systems due to cost of sand media, pump(s) and possible engineering design fees. The land area required may be a limiting factor. Regular (but minimal) maintenance is required. If appropriate filter media are not available locally, costs could be higher. Premature clogging of the filter media can result from exceeding design loading rates.

Operation and Maintenance: Intermittent Sand filters require annual maintenance, although the complexity of maintenance is generally minimal. The majority of operation and maintenance involves monitoring the influent and effluent and checking the dosing equipment periodically. Pumps and controls should be checked every 3 months, and the septic tank or aerobic unit should be checked for sludge and scum buildup and pumped as needed. Regular pumping of the septic tank (every 2-5 yrs) at a cost of \$50-\$100 annually. Annual service contract estimated \$150-\$300 annually.

Estimated Statewide System Costs: \$7,000 to 15,000 (no permit data collected for this system type)

System Type: Septic tank/Pretreatment to Low Pressure Pipe

Basic Design: A low pressure pipe (LPP) system is a shallow, pressure-dosed soil absorption system. LPP systems were developed as an alternative to conventional soil absorption systems to eliminate problems such as clogging of the soil from localized overloading, mechanical sealing of the soil trench during construction, anaerobic conditions due to continuous saturation, and a perched seasonal water table. The LPP system uses several design features to overcome site challenges including: shallow placement, narrow trenches, pressure-dosing with uniform distribution of the effluent, design based on loading, resting and re-aeration between doses. The main components of a LPP system are a septic tank or an aerobic unit, a dosing chamber (a submersible effluent pump, level controls, a high water alarm, and a supply manifold), and small diameter distribution laterals with small perforations (holes). The septic tank is where large solids are removed and primary treatment occurs. Partially clarified effluent then flows by gravity from the tank to a pumping chamber, where it is stored until it reaches the level of the upper float control, which activates the pump with each dose providing 5 to 10 times the lateral pipe volume. The level controls can be set for a specific pumping sequence, or timed dosing, which allows timed breaks between doses and increased time for the soil to absorb the effluent under less saturated conditions. The pump turns off when the effluent level falls to the level of the lower float control. The pumping chamber is usually sized to provide excess storage of at least one day's capacity (above the alarm float) in case there is a power failure or pump malfunction.

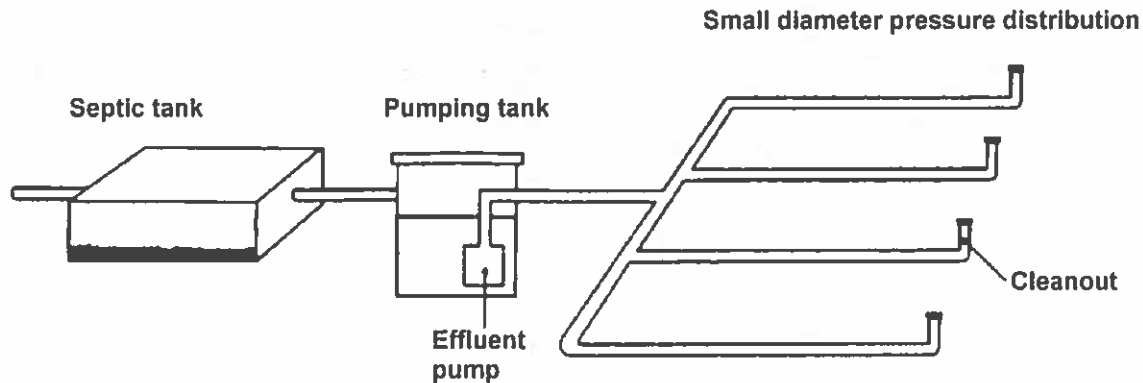

Advantages: Shallow placement of trenches in LPP installations promotes evapotranspiration and enhances growth of bacteria. Improved distribution through pressurized laterals disperses the effluent more uniformly throughout the entire drain field area. Periodic dosing and resting cycles enhance and encourage aerobic conditions in the soil. Shallow, narrow trenches reduce site disturbances and thereby minimize soil compaction and loss of permeability. LPPs allow placement of the drain field area upslope of the home site. The problem of peak flows associated with gravity-fed conventional septic systems is overcome.

Disadvantages: Cost is higher than those of conventional systems due to specialized construction and possible engineering design fees. In some cases, the suitability could be limited by the soils, perched seasonal water table, slope, and space characteristics of the location. A potential exists for clogging of holes or laterals by solids or roots.

Operation and Maintenance: A properly designed and installed LPP system requires very little ongoing maintenance. Regular pumping of the septic tank and pumping chamber (every 2-5 yrs) at a cost of \$50-\$100 annually. Some solids may accumulate at the end of the lateral lines, which should be flushed out once a year. Turn-ups installed at the distal ends of laterals facilitate this process. Annual service contract, if required, between \$100-\$300.

Estimated Statewide System Costs: \$8,000 to 25,000 (no permit data collected for this system type)

System Type: Drip Distribution Systems

Basic design: Drip Distribution Systems are installed very shallow in the soil, at the surface of the ground or on top of a bed of sand, depending on the specific limiting conditions on the property. These systems are pressurized to ensure even distribution of wastewater into the soil. They utilize small diameter tubing with pressure compensating emitters to apply wastewater uniformly over an infiltration surface. Drip Distribution systems are typically split into at least two zones and works on the principle of timed micro-dosing to maintain aerobic conditions in the soil. Timed micro-dosing applies effluent to the soil at uniform intervals throughout a 24-hour period, which allows for improved wastewater treatment. When properly sited, designed, installed and operated, drip systems can help overcome the typical problems associated with uneven wastewater distribution which often result in the surfacing of wastewater in the distribution field, sewage odors and other nuisance conditions.

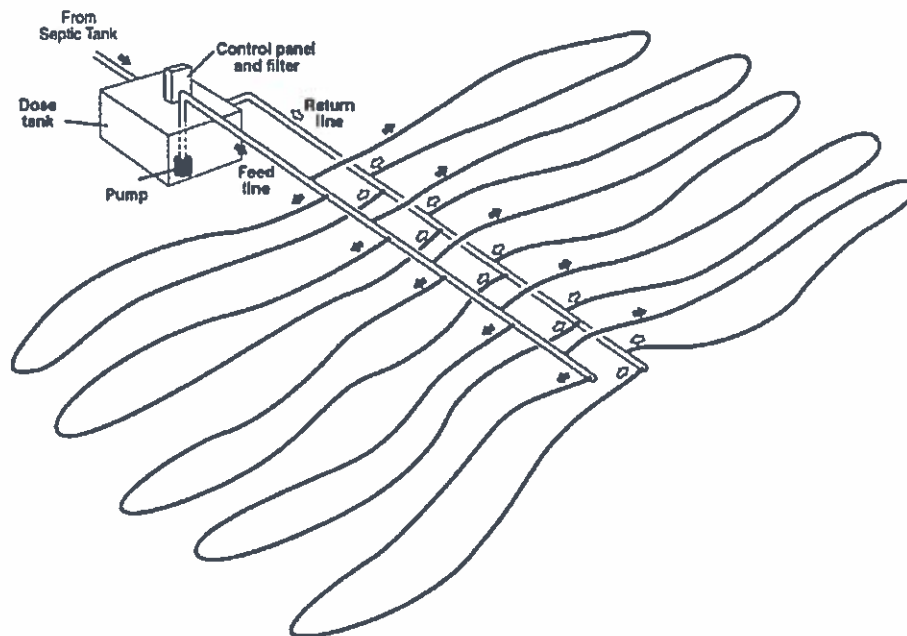

Advantages: Treats sewage and distributes the effluent in smaller doses. These systems can be installed on wooded lots and challenging terrains. Due to the micro-timed dosing of this system this would lessen the likelihood of failure and creating a public health nuisance. The ability to split the soil distribution component into two or more zones allows the use of multiple smaller suitable areas on a lot, thus increasing its probability of being a build able lot.

Disadvantages: These systems require an on-going service contract and are one of the more expensive on-site systems

Operation and Maintenance: Regular pumping of the septic tank (every 2-5 years) at a cost of approximately \$50-100 per year. Most systems require inspection at least twice a yr up to four times a year to monitor flow, system performance, perform system flushing depending on the system configuration. Average Maintenance cost of Drip Distribution Service contract is \$350.00 per yr.

Average Regional System Costs:

Region/Cost	Northwest	Northeast	Southeast	Central	Southwest
2007 LHD Permits	\$18,000	\$19,000	None reported	\$17,500	\$30,000
2007 Installer Survey	\$18,000	\$21,000	\$19,000	\$16,000	\$25,000

System Type: Spray Irrigation System

Basic Design: Spray irrigation is an efficient way to nourish plants and apply reclaimed wastewater to the land; however in order to protect public health and reduce odors, the wastewater must be treated to a very high level before being used in this type of system. Treatment is achieved through the use of septic tanks to waste stabilization ponds, or through mechanical pretreatment and disinfection systems. After treatment, filtration, and disinfection, the effluent is sent under pressure through the mains and lines of the spray distribution system at pre-set times and rates. Vegetation and soil microorganisms metabolize most nutrients and organic compounds in the wastewater during percolation through the first several inches of soil. The cleaned water is then absorbed by deep-rooted vegetation, or it passes through the soil to the ground water. The irrigated area must be vegetated and landscaped to minimize runoff and erosion. When properly designed and installed, most spray systems provide uniform distribution to plants and eliminate discharge to streams. Spray irrigation is sometimes permitted as an alternative wastewater disposal method for sites previously considered unsuitable for onsite systems such as difficult sites with slowly permeable soils, with seasonal perched water or shallow ground water or bedrock, or complex topographies.

Onsite wastewater irrigation system serving a 3-bedroom home at the OSU Molly Caren Agricultural Center near London, Ohio.



Advantages: Because irrigation systems are designed to deliver wastewater slowly at rates beneficial to vegetation, and because the wastewater is applied either to the ground surface or at shallow depths, irrigation may be permitted on certain sites with high bedrock, perched seasonal water tables or shallow groundwater, or slowly permeable soils. Irrigation systems also can be designed to accommodate sites with complex terrains. Spray irrigation saves on potable water because the wastewater is used for irrigation. Above-ground spray system components are easier to inspect, control, and service than subsurface drip irrigation components.

Disadvantages: Cost is higher than those of conventional systems. Temperature factors in some areas of the country may preclude the use of spray irrigation during certain times of the year. The wastewater may need to be stored in holding tanks during the coldest period of the year, because plant growth is limited and the nitrogen in effluent discharged during this time will be mineralized and unavailable for plant uptake. Sites near surface water or shallow groundwater often are restricted, especially when these are used as drinking water sources. Depending on the level of treatment, spray systems generate aerosols, therefore, regulations may require large separation distances or buffer zones that make spray systems inappropriate for small lots. Minimum setbacks of as much as 50 feet of forested buffer or 150 to 500 feet from neighboring residences and water sources are not unusual.

Operation and Maintenance: On a monthly basis, the owner should walk over the spray area and look for ponding of effluent, bad odors, damage to spray heads, surfacing liquids, vegetation problems, surface soil collapse. On quarterly to biannual basis, the system should be checked for proper spray sequence, pump function, and liquid levels. The system should be tested annually to determine treatment levels. A management contract with an approved operator or operations firm is also suggested. O&M estimated at \$300-\$400 annually but may be less depending on the type of pretreatment used.

Estimated Statewide System Costs: \$15,000 to 20,000 (no permit data collected for this system type)

System Type: **Constructed Wetlands**

Basic Design: Constructed wetlands are non-mechanical pretreatment systems following a septic tank. These systems are designed and constructed to utilize the natural processes involving wetland vegetation, soils, and their associated microbial assemblages to assist in treating wastewater. A constructed wetland system (CWS) pre-treats wastewater by filtration, settling, and bacterial decomposition in a natural-looking lined marsh. Subsurface Flow Systems are designed to create subsurface flow through a permeable medium, keeping the water being treated below the surface, thereby helping to avoid the development of odors and other nuisance problems. The media used (typically soil, sand, gravel or crushed rock) greatly affect the hydraulics of the system. The wetland treatment systems are typically constructed in basins or channels with a natural or constructed subsurface barrier to limit seepage. The components of a complete system include: a septic tank for primary settling of the wastewater; a bermed or retained cell(s) that contains an impermeable liner, a gravel substrate, mulch and water-loving plants and a distribution system. Constructed wetlands are typically used as a pretreatment component before discharge to a soil absorption system. These systems are able to reduce biochemical oxygen demand (BOD), total suspended solids (TSS) and fecal coliforms. However, this pretreatment device has not been approved statewide in Ohio for soil absorption or soil depth credits.

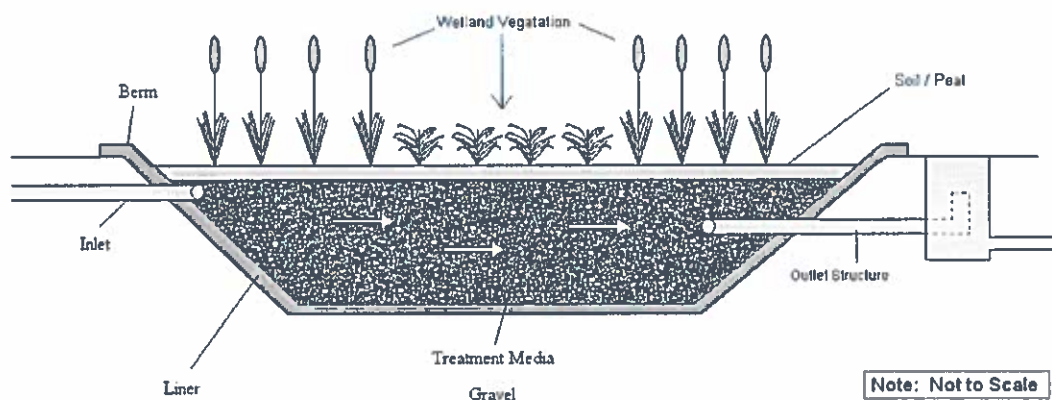

Advantages: Under the right site conditions, constructed wetlands can be an affordable alternative to conventional wastewater treatment systems. Constructed wetlands can be an effective natural method for wastewater treatment and are generally simple to build and maintain. Wetlands require little or no energy to operate and provide effective secondary effluent treatment. They are passive systems that do not require much routine maintenance. Constructed wetlands generally do not have any odors.

Disadvantages: Constructed wetlands are site-specific; expert design and additional calculations to determine the economics are advised. Because year-round flow is necessary to sustain the plants, constructed wetlands are not appropriate for seasonal residences. In colder climates larger cells are needed for freeze-prevention design, and efficiency will be compromised. On steep slopes, cut-and-fill may be necessary to keep the effluent flow slow enough for proper absorption. Potential slow initial start-up period before vegetation is adequately established every year. Burrowing animals may pose a threat. All external sources of flow, including precipitation, affect sizing of these systems.

Operation and Maintenance: Overall operational costs of Subsurface Flow Constructed Wetlands range from \$200-\$500 per year which includes pumping the tank, repairs, maintenance, and electricity. A routine schedule should be developed to inspect the wetland for any plants that are invasive, noxious, or fibrous. Regular pumping of the septic tank (every 2-5 yrs) at a cost of \$50-\$100 annually.

Estimated Statewide System Costs: \$6,500 to 7,500 plus the cost of the soil absorption area (no permit data collected for this system type)